

WOLONG

Power your future



Oil Well Pump Motors

NEMA D
3 Phase, 60 Hz
460V
3 - 150 HP



NEMA D Motors

High Slip, High Torque Design



Wolong oil well pump motors are designed with high slip (5-8%) and high torque (NEMA D) to meet the requirements of oil beam pumping units. With minimal maintenance and stock availability, these motors have become an obvious choice for operators.

- Rugged cast iron frame
- Opposite drive end bearing locked for high axial thrust capacity
- F2 conduit box position, convertible to F1
- Regreasable bearings

Wolong motors are engineered, tested, and proven to meet all applicable NEMA and CSA requirements and standards for oil pump applications.



Features

Type	AC Induction
Phase	3
Frequency	60 Hz
Voltage	460 V
Power	3 to 150 HP
Speed	1200 RPM
Enclosure	TEFC, IP55
Efficiency	Standard Efficiency
Insulation	Class F

Ambient	40°C
S.F. Factor	1.15 (continuous)
Temp Rise	Class-B @ 1.0 service factor
VFD	Inverter Duty - 2:1 speed range in constant torque operation
Brg Type	Anti-friction ball, Drive end roller at 50 HP and above
Shaft	AISI 1045 steel
Haz. Area	Safe Area
Hardware	Corrosion-resistant
Warranty	12 Months

▼ Ratings and Dimensions

213 - 404
Frames

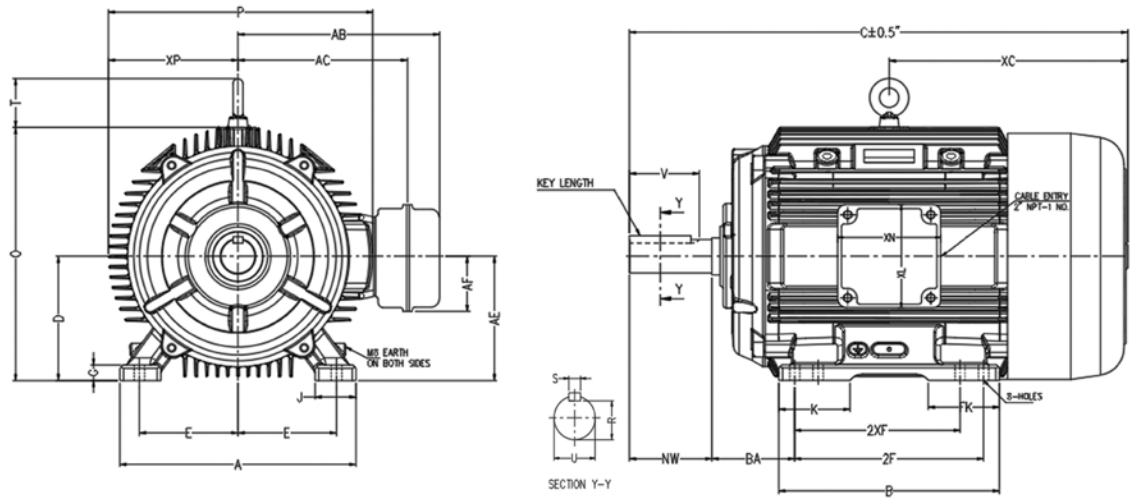

444 - 447
Frames

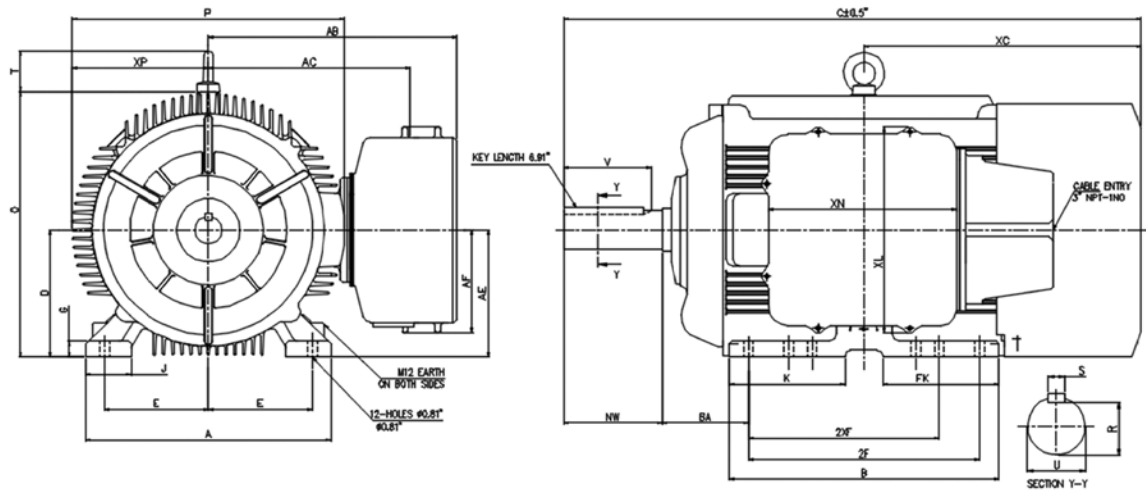

HP	Speed (RPM)	Enclosure	Frame	Bearings	Cat #	Model #	U Dia. (in)	2F (in)	2E (in)	D (in)	BA+NW (in)
3	1200	TEFC	ND213T	Ball	S2000	5KR213SCG308	1.37	5.50	8.00	5.00	7.00
5	1200	TEFC	ND215T	Ball	S2001	5KR215SCG308	1.37	6.70	8.00	5.00	7.00
7.5	1200	TEFC	ND254T	Ball	S2002	5KR254SCG308	1.62	8.20	10.00	6.00	8.30
10	1200	TEFC	ND256T	Ball	S2003	5KR256SCG308	1.60	10.00	10.00	6.00	8.30
15	1200	TEFC	ND284T	Ball	S2004	5KR284SCG308	1.90	9.50	11.00	7.00	9.35
20	1200	TEFC	ND286T	Ball	S2005	5KR286SCG308	1.90	11.00	11.00	7.00	9.50
25	1200	TEFC	ND324T	Ball	S2006	5KR324SCG308	2.10	12.00	12.00	8.00	11.00
30	1200	TEFC	ND326T	Ball	S2007	5KR326SCG308	2.10	12.00	12.00	8.00	11.00
40	1200	TEFC	ND364T	Ball	S2008	5KR364SCG308	2.40	12.00	14.00	10.00	11.90
50	1200	TEFC	ND404T	Roller	S2009	5KR404SCG308	2.90	14.00	16.00	10.00	14.30
60	1200	TEFC	ND404T	Roller	S2010	5KR404SCG309	2.90	14.00	16.00	10.00	14.30
75	1200	TEFC	ND444T	Roller	S2011	5KR444SCG309	3.37	20.00	18.00	11.00	16.35
100	1200	TEFC	ND444T	Roller	S2012	5KR444SCG310	3.37	20.00	18.00	11.00	16.35
125	1200	TEFC	ND445T	Roller	S2013	5KR445SCG308	3.37	20.00	18.00	11.00	16.35
150	1200	TEFC	ND447T	Roller	S2014	5KR447SCG308	3.37	20.00	18.00	11.00	16.35

WOLONG

Power your future



www.wolongamerica.com

GE is a trademark of General Electric Company. Manufactured under trademark license.
©2023, Wolong Electric America LLC. All rights reserved
GEA33478-EN (2/2023)